



100L

Installation and Operation Manual

WARNING

!!!! READ THIS BEFORE INSTALLING THE UNIT !!!!

All un-vented water heating systems above 15 litres (this includes the Water Hotter Hot Water ASHP's) **MUST** be installed to meet the requirements of the local area Building Regulations. It is a legal requirement that the local Building Control Officer be notified of any proposed installation of un-vented water heating systems over 15 litre capacity.

Furthermore, it must be fitted by an installer who has successfully completed a recognised course in the installation of un-vented heating systems such as CITB and be familiar with installing the Water Hotter unit. **Failure to properly fit the unit may affect its safety, efficiency and invalidate any guarantee.**

Safety requirements in the UK call for an expansion space (internal or external), safety devices to prevent the stored water exceeding 100°C, and pipe work to convey discharged hot water safely away from the safety devices.

THE UNIT MUST BE INSTALLED, COMMISSIONED AND MAINTAINED BY A COMPETENT INSTALLER IN ACCORDANCE WITH BUILDING REGULATION G3 (ENGLAND AND WALES), TECHNICAL STANDARD P3 (SCOTLAND) OR BUILDING REGULATION P5 (NORTHERN IRELAND) AND THE WATER FITTING REGULATIONS (ENGLAND AND WALES) OR WATER BYELAWS (SCOTLAND). FOLLOWING INSTALLATION AND COMMISSIONING, THE OPERATION OF THE UNIT SHOULD BE EXPLAINED TO THE USER AND THESE INSTRUCTIONS LEFT WITH THEM FOR FUTURE REFERENCE.

Contents Page	
	1.0 Preface
	2.0 General Notes
	2.1 Safety Precautions
	2.2 Installation Notes
	2.3 Operating Notes
	2.4 Moving and Repair Notes
	2.5 Siting and Safety Notes
	2.6 General Requirements
	3.0 Siting the Unit
	3.1 Heat Source
	3.2 Dehumidification
	3.3 Cooling
	3.4 Siting Guidance
	4.0 Installation
	4.1 Ducting
	4.2 Water Supply
	4.3 Outlet Fittings
	4.4 Limitations
	4.5 Regulations
	4.6 Package Contents
	5.0 Specifications
	5.1 Appearance
	5.2 Features
	6.0 Technical Specifications
	7.0 Performance
	7.1 Technical Performance
	7.2 Standing Heat Losses
	7.3 DHW Recovery Times
	7.4 Performance Graphs
	8.0 Functions
	9.0 Physical Installation

- 9.1 Schematic Diagram
- 9.2 Pipe Fittings
- 9.3 Cold Water Supply
- 9.4 G3 Requirements
- 9.5 G3 Guidance
- 10.0 Moving the unit
 - 10.1 Storage and Transport
 - 10.2 Using a Forklift
 - 10.3 Transporting for Installation
- 11.0 Hydraulic Connection
 - 11.1 Connection Diagram
- 12.0 Wiring
 - 12.1 Wiring Diagram
 - 12.2 Earthing
- 13.0 Operating the Unit
- 14.0 Troubleshooting
- 15.0 Maintenance
 - 15.1 The Cylinder
 - 15.2 Safety Valves
 - 15.3 The Strainer
 - 15.4 Draining The Unit
 - 15.5 Descaling the Immersion
 - 15.6 Refilling the Unit
 - 15.7 Log Book
 - 15.8 Maintenance Requirements.
- 16.0 Fault Finding
- 17.0 Guarantee
 - 17.1 Guarantee Terms
- 18.0 Environmental Information
- 19.0 Spare Parts

1.0 PREFACE

- *This manual includes the necessary information about installation and maintenance of the Water Hotter. **Please read this manual carefully before you install or carry out maintenance on the unit.***
- *When installing the unit, please carry out the work strictly in accordance with the manual, relevant Regulations and good practice.*
- *Please do not switch the unit on until you are sure that it has been properly installed, electrically and mechanically and there is water in the system.*
- *The installer should explain to the end user how to operate and maintain the unit before handing over the unit to the end user. Also, the installer should advise the end user to read the manual fully before operating the unit.*
- *Further, improper installation, operation and/or maintenance, and failure to maintain the unit as per this manual will invalidate any unit warranty or guarantee.*
- *The manual may be altered and/or updated in any way at the sole discretion of the supplier and/or Water Hotter without notice.*

2.0 GENERAL NOTES

2.1 Safety Precautions

Below you will find information that is critical for the safe and proper installation and use of the unit. Please make sure that you understand the contents because it is written to help avoid the risk of injury or damage to the unit/other property.

2.2 Installation Notes

Professional & qualified installer is required	The heat pump must only be installed by a suitably qualified engineer. Failure to ensure this can cause damage to the unit and may cause serious injury. The warranty on the unit will also be invalidated if a suitably qualified engineer is not engaged to install it.
Earthing required	Please make sure that the unit and power supply are properly earthed.
Refrigerant	If you are installing the unit in a small room, please give full consideration to adequate ventilation being available in the event of a refrigerant leak.
Installation Site	Do not install the unit near a gas installation. This unit is designed to be installed inside a building.
Site consideration	Ensure that this unit is fixed securely to a suitable wall that is capable of taking the load of the unit when full of water. Make sure that you have a suitable facility to cater for the disposal of condensate from the condensate drain on the unit.
Circuit Breaker	Make sure that this unit is connected to the power supply via a fused switched spur and a 13A Type C MCB.
Unit Upright	The unit <u>must</u> be installed level across the whole diameter. Failure to install the unit level will mean that condensate can spill over the lip of the cylinder.

2.3 Operating Notes

Do NOT	Do not push anything into the fan blades when running and make sure that children cannot access the unit or play close to the unit.
Shut off the power supply	If there is an unusual sound or smell coming from the unit, shut off the power supply immediately and call your installation engineer.

2.4 Moving and Repair Notes

Caution	This unit has a high centre of gravity. This unit must be strapped down to prevent it falling over when in transit.
Suitably qualified engineer	When moving the unit or carrying out repair work please be sure to use only a suitably qualified engineer.

Do NOT	Do NOT try to install, move or repair the unit yourself – it is NOT worthwhile running the risk of injury.
Transporting the Unit	The unit must be transported in the vertical position. It can be tilted up to 60° from the horizontal axis (see section 11.3).

2.5 Siting and Safety Notes

Siting the Unit	The unit must only be installed indoors – the unit is not designed for, or suitable for installation outside. The Unit needs to be sited where the ambient temperature never goes below 5 degrees. If the unit is to be left unused for any significant period of time during which the ambient temperature could cause the unit or pipe work from the unit to freeze, it should be drained down.
Shut off the power	When cleaning the unit, shut off the power supply.
You MUST	You must use a suitable power supply that is appropriately fused.

2.6 General Requirements

IMPORTANT: PLEASE READ AND ENSURE THAT YOU UNDERSTAND THESE INSTRUCTIONS BEFORE INSTALLING THE Water Hotter (“DHW ASHP” or “unit”). INCORRECT INSTALLATION WILL INVALIDATE ANY GUARANTEE.

PLEASE NOTE THAT THERE ARE ESSENTIALLY 2 UNITS COMBINED INTO ONE IN THE WATER HOTTER AND YOU MUST BE SURE TO UNDERSTAND BOTH ELEMENTS - THE INDIRECT HOT WATER CYLINDER AND THE AIR SOURCE HEAT PUMP. PLEASE ALSO NOTE THE WATER HOTTER CAN BE INSTALLED IN EITHER A VENTED OR UNVENTED SYSTEM

IMPORTANT NOTE: DO NOT SITE THE UNIT IN THE SAME ROOM AS AN APPLIANCE WITH AN OPEN FLUE OR IN A ROOM FROM WHICH AN OPEN FLUED APPLIANCE TAKES ITS COMBUSTION AIR, UNLESS THE

MATTER HAS BEEN CAREFULLY CONSIDERED AND ADEQUATE DUCTING AND VENTILATION HAS BEEN PROVIDED FOR THE UNIT (THE DHW ASHP) AND THAT THE OPEN FLUED APPLIANCE IS FULLY CATERED FOR IN TERMS OF SUITABLE AIR SUPPLY.

Please be sure to use appropriate lifting equipment when moving the unit.

3.0 SITING THE UNIT

The unit is designed to be wall mounted. It can be placed anywhere convenient provided the discharge pipe(s) from its safety valves and air handling duct work can be correctly installed. Areas that are subject to freezing must be avoided. Ensure that the wall is of sufficient strength to support the weight of the unit when full with water. Pipe run lengths should be kept as short as possible for maximum economy and efficiency: the use of secondary returns should be avoided. Access to associated controls and indirect controls must be possible for servicing and maintenance of the unit. Please do not install valves or pipe work (except discharge pipe) within 50mm (2") of the T&P relief valve to allow insulation to be fitted. The insulation is important to avoid heat loss.

Consideration must be given to the use of insulated ducting to carry air to and from the unit. Insulated ducting must be used where condensate may form on the duct work.



3.1 Heat Source

The Water Hotter can receive ducted waste heat from another area in the building – duct work can be fixed to the top of the unit and may be up to 8m long without an additional in-line fan in the ductwork being needed. The Water Hotter can also draw heat from the room in which it is sited. (See Picture 1)

Always be sure to site the unit and arrange duct work to allow adequate heat availability to allow the Water Hotter to operate efficiently (inlet air should not be below 8° C.)

The secondary coil in the Water Hotter enables direct connection to a second stable heat source, e.g. a solar heating system or a boiler.

Under no circumstances is the Water Hotter to be installed onto an uncontrolled heat source e.g wood burner or back boiler

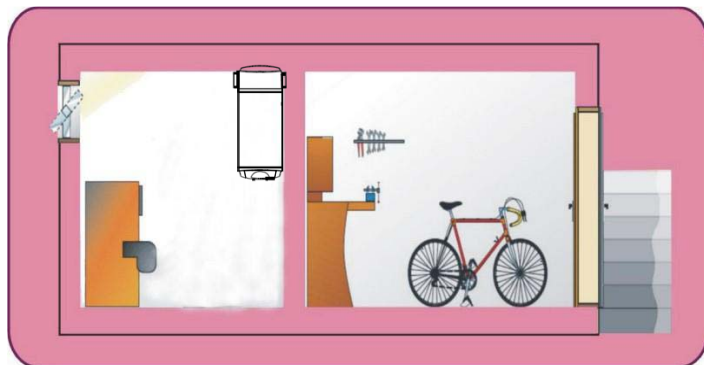

Picture 1

3.2 Dehumidification – The Water Hotter can be used to dehumidify rooms that are hot and damp – e.g. Laundry room (See Picture 2). The unit is equipped with a condensate drain that must be properly directed to a suitable waste pipe where the condensate water (non acidic) can drain away. If the drain is into a main sewer it must have a trap installed to prevent back smell through the Water Hotter.



Picture 2

3.3 Cooling (picture 3)

The Water Hotter can extract warm air and place cooled, dehumidified, outlet air back in to the same room – this is perfect for cellars and gymnasiums. Any cold air exhaust air ducting must be lagged when passing through a warmer

area to prevent the formation of condensate. All ducting should be 150mm or split into two 75-80mm ducts.



Picture 3

3.4 Siting Guidance

1. Decide upon the right route to be taken to move the unit in to the chosen position.
2. Try to move the unit in its original case to avoid damage.
3. Be sure to have the unit and electrics fitted by qualified electrician.
4. **Ensure that no building materials or debris are allowed to enter the air ducts at the top of the unit or any extension of the ducts.**

4.0 INSTALLATION

4.1 Ducting

Air ducts to and from the heat pump should be 150mm pipe.

The outlets should be fitted with a suitable gravity vent to prevent rain, debris, animals and plants entering the ducts.

You can use rigid or flexible ducting. It is always best to use insulated ducting so that condensation is avoided.

When servicing the unit, ducting should be checked to make sure that it is clear and obstructions removed.

4.2 Water Supply

Bear in mind that the mains water supply to the property will be supplying both the hot and cold water requirements simultaneously. Therefore, it is important that the maximum water demand be assessed and the water supply checked to ensure that it can meet peak demand.

NOTE: *A high mains water pressure will not always guarantee high flow rates. The main supply pipe to the unit must be in 22mm. The minimum mains water supply requirements should be 0.15 MPa (1.5 bar) working pressure and 20 litres per minute flow-rate at the unit. At these levels, outlet flow rates may be poor if several outlets are used simultaneously - the higher the available pressure and flow-rate the better the system performance will be.*

The unit has a design operating pressure of 3 bar which is controlled by the Cold Water Combination Valve on the cold water feed pipework. The Cold Water Combination Valve can be connected to a maximum mains supply pressure of 1.6 MPa (16 bar). The water supply must be of wholesome water quality (Fluid Category 1 as defined by the Water Supply Regulations 1999).

The unit MUST be level horizontally, and vertically upright, otherwise this could cause problems with condensate draining from the heat pump section of the unit into the condensate drain.

An inline strainer (if open vented) and scale inhibitor (WRAS approved) must be fitted "in line" on the water supply to the unit. Failure to fit these will invalidate the unit warranty/guarantee. All fittings must be WRAS approved.

If installing the unit in unvented configuration, an “unvented Pack”, containing the required safety valves must be supplied with the unit and there is likely to be an additional cost for this.

4.3 Outlet Fittings

The unit can be used in conjunction with most types of terminal fittings. It is helpful in many mixer showers to have balanced hot and cold water supplies; in these instances the balanced cold water supply can be taken from the tapping on the combination valve. Branches to cold drinking water outlets should be taken before the combination valve.

NOTE: Accessories should have a rated operating pressure of at least 0.8 MPa (8 bar).

4.4 Limitations

The unit should not be used in any of the following instances:

- With a water supply from solid fuel boilers or any other boiler in which the energy input is not under effective thermostatic control, unless additional, necessary and appropriate safety measures are installed.
- With gravity circulation primaries unless a good head of pressure is available.
- With a steam heating plant unless additional and appropriate safety devices are installed.
- With ascending spray type bidets or any other facility where there is a Class 5 back-siphoning risk requiring that an appropriate air gap be employed.
- With water supplies that have either inadequate pressure or where the supply may be intermittent.
- In situations where it is not possible to pipe away any discharge from the safety valves safely.

- In areas where the water contains a high proportion of solids, e.g. suspended matter that could block the strainer, unless adequate filtration can be ensured.
- Where another appliance in the room is vented by way of an open flu.

The installation must be carried out in accordance with the relevant requirements of:

- A) The appropriate Building Regulations: either The Building Regulations (England and Wales), The Building Regulations (Scotland) or Building Regulations (Northern Ireland).
- B) The Water Fittings Regulations (England and Wales) or Water By-laws (Scotland).
- C) Any other applicable Regulations.

Failure to observe any of the above conditions will invalidate the warranty/guarantee.

4.5 Package Contents

Where the unit is to be installed as an unvented system it will be supplied with the fittings needed to allow installation to comply with G3 Regulations – This means that the supply cost for the unvented configuration unit will be higher than when installed as a vented system as additional fittings are required. Where the unit is to be installed in a vented system, such fittings will not be necessary.

5.0 SPECIFICATIONS

5.1 Appearance

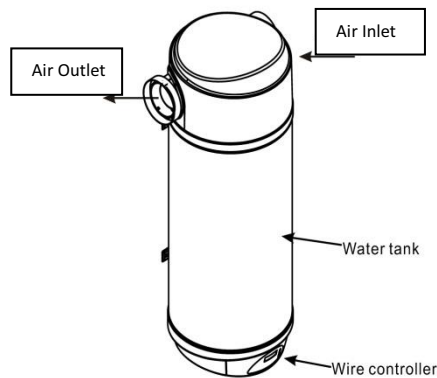

5.2 Features

Good Looking and Efficient

The attractive design allows the unit to be placed in the open in finished utility spaces and basements; depending on ambient conditions, the cost of operation can be up to 75% less of that of an electric water heater, and can be used in locations unsuitable for solar hot water heating.

Environmentally friendly and safer

The unit produces no harmful emissions locally; there is no combustion of oil, coal, or natural gas. No carbon monoxide is produced and there is no open flame.

Easy to operate and multiple heat sources

The Water Hotter is equipped with a timer for automatic start-up and stop and an adjustment for setting of water temperature easily. The unit can take heat from a number of sources in domestic installations, or from hot areas in light industrial environments.

6.0 TECHNICAL SPECIFICATIONS

ESP400-003-100L(D)

Unit: mm

Spec. Dimension	ESP400-003-100L(D)
A	1305
B	985
C	Φ520
D	520

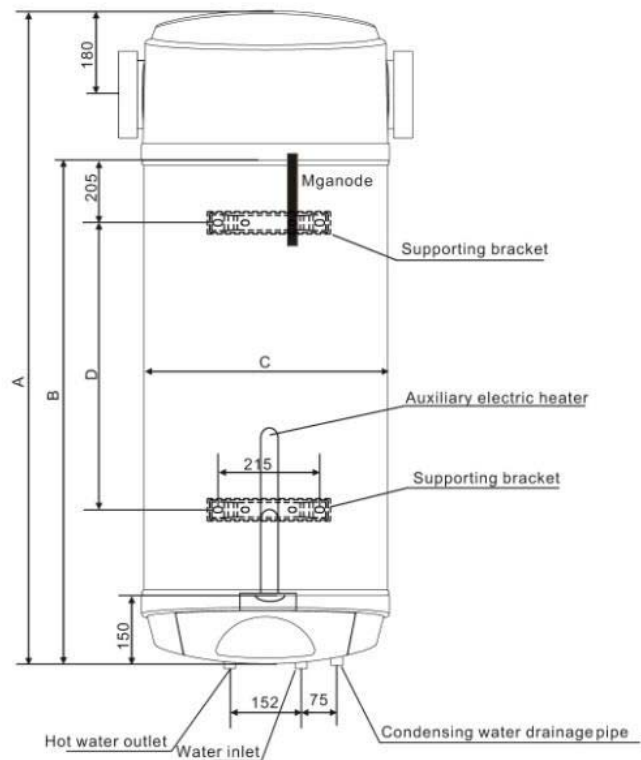

7.0 PERFORMANCE

7.1 Technical Performance

Model		Water Hotter400-003-100L(D)
Heating capacity	kW	1.0
Water tank capacity	L	100L
Power input	kW	0.27
Running current	A	1.2
Power supply		230V~/50Hz
Compressor number		1
Compressor Type		Rotary
Rated outlet water temp.	°C	55
Noise	dB(A)	45
Water inlet/outlet size	inch	1/2
Net dimensions	mm	see the diagram
Shipping dimensions	mm	see package label
Net weight	kg	see nameplate
Shipping weight	kg	see package label

Standard working conditions:

Ambient temperature of dry bulb/wet bulb: 15° C /13° C

Rated water outlet temperature: 45° C.

Working scope: Peak water outlet temperature: 60° C

Running Current is quoted without Immersion Heater.

Immersion heater is rated at 1kW

Operating parameters:

Acceptable scope of water setting temperature: 9° C ~70° C

Acceptable running pressure of the water tank: 0.1~1.0MPa

Maximum inlet water pressure: 0.7MPa

7.2 Standing Heat Losses

The amount of heat that the Water Hotter loses through convection to the surrounding area (standing heat loss) is dependent on a number of things including, for example, the target temperature and the ambient air temperature surrounding the unit. The target temperature is an end user choice and the ambient temperature will depend on location; clearly if the unit is in an 'airing cupboard', the ambient temperature will be higher than if it is located in, say, a utility room; the higher the ambient air temperature, the lower the rate of heat loss. However, an illustrative heat loss for the Water Hotter is 1.09 kWh per 24hrs in an 'average' location of 20°C and a target temperature of 55°C.

7.3 DHW Recovery times

The recovery time of your 100ltr Water Hotter (the time it takes to return to fully hot) depends on the storage temperature (normally 55°C), the temperature of your cold water supply (normally taken to be 10°C), the temperature of the air supply (at least 15°C) and the amount of water you use. Typically, a single person uses about 45l of hot water per day. However, it would be unusual to use all this hot water at the same time. A shower uses around 30l and a bath uses around 65l. The recovery times based on proscribed test data are as follows:

Volume	Time
10l	32 mins
15l	47 mins
20l	63 mins
30l	95 mins
40l	126 mins
65l	205mins

But, because the Water Hotter unit uses waste heat, the expected recovery times are likely to be much shorter and the following table is indicative of more normal recovery times:

Volume	Time
10l	24 mins
15l	36 mins
20l	48 mins
30l	72 mins
40l	97 mins
65l	157mins

In fact, the recovery times could well be even better than this because the air source will probably warmer than used to calculate the above tables.

Your Water Hotter unit will have been sized based upon normal DHW use profiles and volumes and, save in exceptional circumstances (e.g. visitors using shower/bath), you should not run out of hot water. Should your usage exceed normal expectation, the immersion heater can be used to provide a boost by selecting the rapid heating mode. In fact, in the unusual event that the target temperature (normally 55°C) is not reached within 45 mins, the immersion heater will automatically provide that boost.

7.4 Performance Graphs

100 Ltr Water Hotter Output Curve

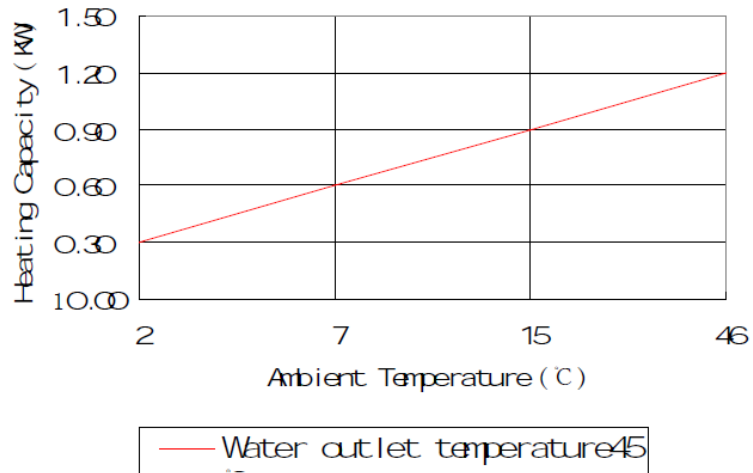

100 Ltr Water Hotter COP Curve

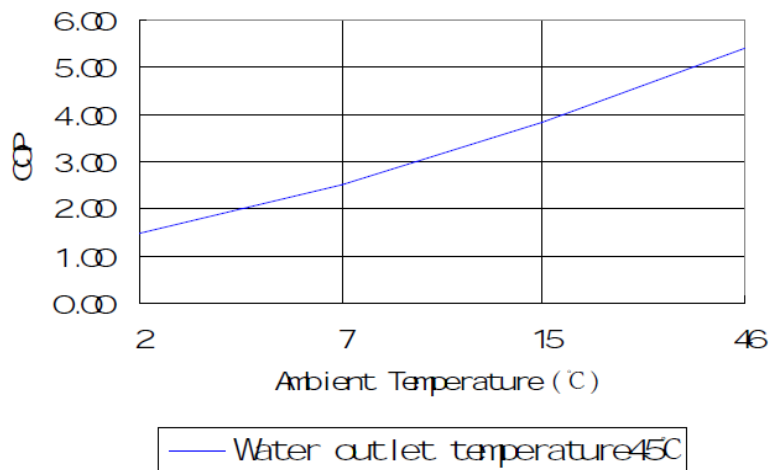

8.0 FUNCTIONS

Heating Capacity

The unit absorbs energy from the air taken in through the inlet ductwork. If the air inlet temperature is low, heating capacity will show a variation from standard conditions.

3 Minutes Protection

When the unit stops, if you try to immediately restart the unit or turn on the manual switch, the unit will not run for 3 minutes. This is built in protection for the compressor.

Heating Mode Operating

If the ambient temperature is very high, to protect the unit, the fan motor will stop running.

Defrosting

When in heating mode, the unit will defrost automatically, if required. The fan motor will stop running when the unit is defrosting.

Working Conditions

The unit should be run in ambient temperatures of 0-40 deg. The unit includes sophisticated electronic devices - **do not** fill the Water Hotter with water from a lake, river water or groundwater and **be sure to put an inline strainer (open vented) and scale inhibitor in the cold water feed** - failure to do so will invalidate the warranty/guarantee.

9.0 PHYSICAL INSTALLATION

9.1 Schematic Diagram

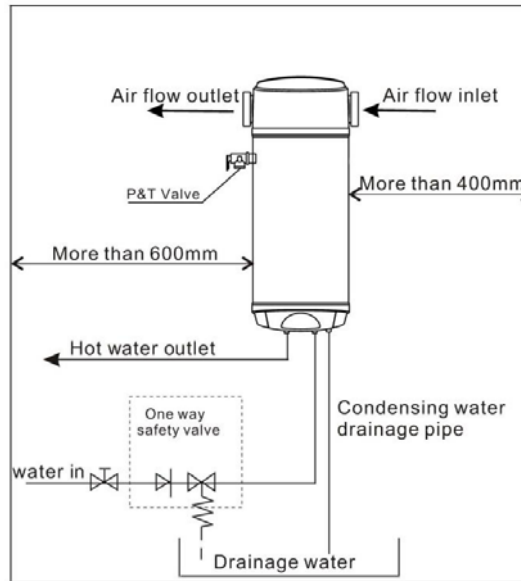

9.2 Pipe Fittings

Supply and Flow pipes to and from the unit *must* be attached using the supplied flexi-hoses.

Air ducts must be at least 150mm in internal diameter. It is recommended that you use insulated ducting on both inlet and outlet ducts.

9.3 Cold Water Supply

Because water composition can vary greatly, **it is not Water Hotter's policy to issue recommendations relating to water treatment**. The user or the owner is responsible for contacting a specialised water treatment company to obtain water treatment advice appropriate to your location. Appropriate

water treatment processes/devices must be fitted to ensure the longevity of the unit and its proper operation.

A 22mm cold water supply is recommended, however, if a 15mm (1/2") supply exists which provides sufficient flow it may be used. More flow noise may be experienced from small bore pipes due to the increased water velocity through them.

The Cold Water Combination Valve supplied with the unit incorporates a full flow isolating valve which will enable the unit to be isolated from the mains supply for maintenance or servicing. To close the valve the black handle should be turned so that it lies at 90° to the direction of flow. To open turn the handle so that it lies parallel to the direction of flow.

An inline filter (open vented) and an effective scale prevention device should be fitted.

9.4 G3 Requirement

G3 (ENGLAND AND WALES), TECHNICAL STANDARD P3 (SCOTLAND) OR BUILDING REGULATION P5 (NORTHERN IRELAND) AND THE WATER FITTING REGULATIONS (ENGLAND AND WALES) OR WATER BYELAWS (SCOTLAND).

There shall be precautions to ensure that the hot water discharged from safety devices is safely conveyed to where it is visible but will not cause danger to persons in or about the building.

9.5 G3 Guidance

The installation should include the discharge pipe(s) (D1) from the safety device(s). In either case the tundish should be vertical, located in the same space as the unvented hot water storage system and be fitted as close as possible and within 500mm of the safety device(s) e.g. the TPRV.

The discharge pipe (D2) from the tundish should terminate in a safe place where there is no risk to persons in the vicinity of the discharge, and be of metal

- a) be at least one pipe size larger than the nominal outlet size of the safety device unless its total equivalent hydraulic resistance exceeds that of a straight pipe 9m long i.e. discharge pipes between 9m and 18m equivalent resistance length should be at least two sizes larger than the nominal outlet size of the safety device, between 18 and 27m at least 3 sizes larger, and so on. Bends must be taken into account in calculating the flow resistance. Refer to Diagram 7 and Table 1 below. An alternative approach for sizing discharge pipes would be to follow BS6700:1987 Specification for design, installation, testing and maintenance of services supplying water for domestic use within buildings and their curtilages, Appendix E, section E2 and table 21.
- b) have a vertical section of pipe at least 300mm long below the tundish before any elbows or bends in the pipe work.
- c) be installed with a continuous fall, and in a frost free environment.
- d) have discharges visible at both the tundish and the final point of discharge, but where this is not possible or is practically difficult there should be clear visibility at one or other of these locations.

iii. discharges at high level; e.g. into a metal hopper and metal down pipe with the end of the discharge pipe clearly visible (tundish visible or not) or onto a roof capable of withstanding high temperature discharges of water and 3m from any plastic guttering system that would collect such discharges (tundish visible).

iv. where a single pipe serves a number of discharges, such as in blocks of flats, the number served should be limited to not more than 6 systems so that any installation discharging can be traced reasonably easily. The single common discharge pipe should be at least one pipe size larger than the largest individual discharge pipe (D2) to be connected. If unvented hot water storage systems are installed where discharges from safety devices may not be apparent i.e. in dwellings occupied by blind, infirm or disabled people, consideration should be given to the installation of an electronically operated device to warn when discharge takes place.

10.0 MOVING THE UNIT

10.1 Storage and Transportation

Generally, it's better to use a container to transport hot water heat pumps and store them in a suitable and dry place.

10.3 Using a Forklift

When using forklift to carry the unit it must be on a pallet and the operator should try to keep the height of forklift at the lowest possible level because unit is top-heavy.

10.3 Transportation for Installation

The unit must be kept at vertical for at least 1 hour before you attempt to start it.

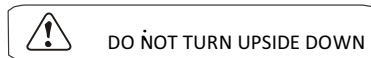
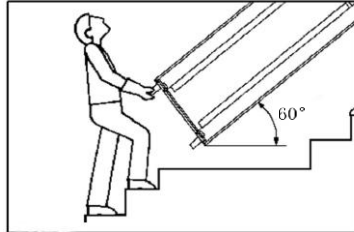

11.0 Hydraulic Connection

Please bear the following points in mind when connecting the water pipes:

- The inner surface of all pipes should be clean, with no oxidization or dirt to restrict flow. After connecting pipes, please check the whole system for leaks before applying insulation.
- Install one-way valves and safety valves in the distribution system.
- All pipework must be installed in accordance with DIN1988. To avoid too high a water pressure, please install a discharge valve.
- Ensure that debris does not enter the distribution pipework during installation.

The drain valve should be operated periodically (using the handle) to ensure that it does not jam and is free of sediment. Care should be taken as the discharge water will be hot. The drainage pipe should be well insulated and checked periodically to minimise the risk of blockage. Blockage could lead to a system failure.

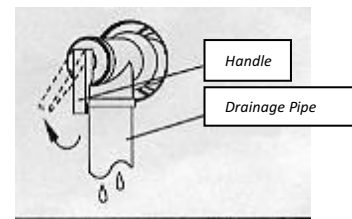

11.1 Installation Diagram

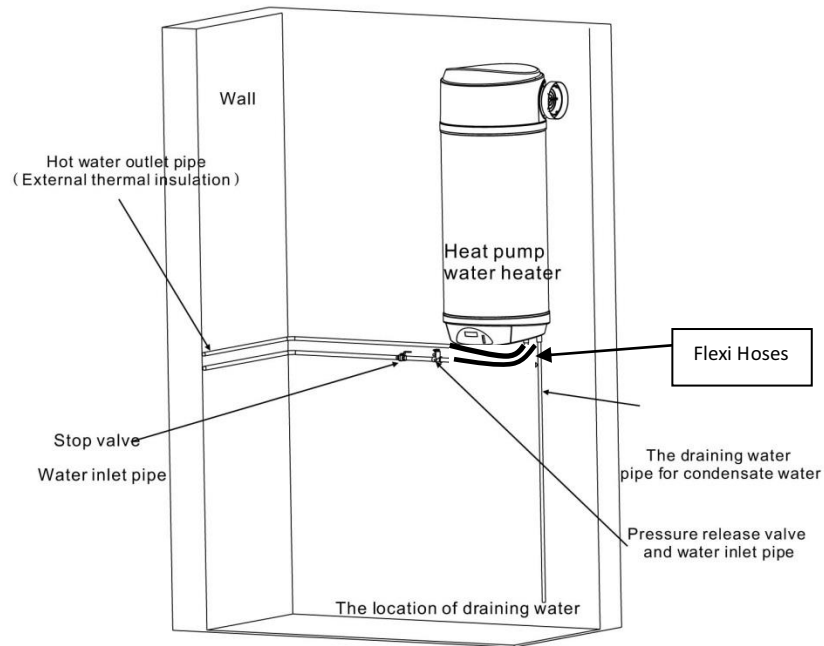

Accessories provided: safety release valve.

ATTENTION !

After installing the pipework in accordance with the above diagram, open the closest hot water tap and stop valve to fill the vessel. This will purge the system of air and the process can take up to 20mins. When no more air escapes from the hot water tap, the tap can be turned-off and the system should have been fully purged.

12.0 WIRING

12.1 Wiring Diagram

All electrical wiring **MUST** be carried out by a qualified electrician and conform to the latest I.E.E. Wiring Regulations. The wiring block diagram is set out below in diagram 14.

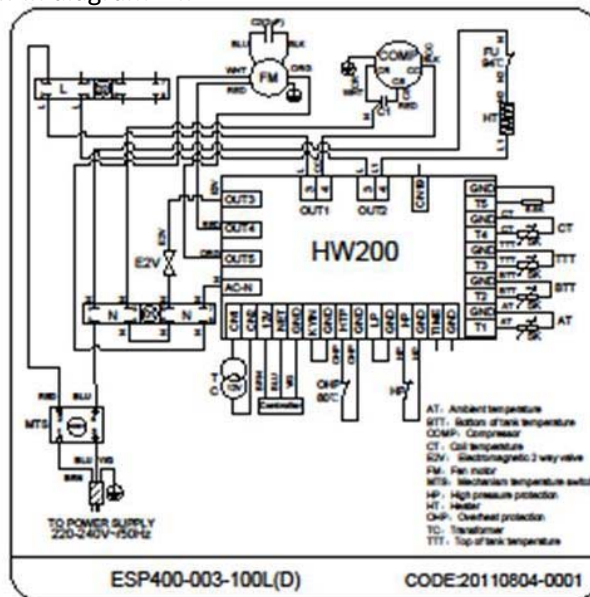

Diagram 14

Great care should be taken to ensure that the unit is properly wired to the mains electricity and any auxiliary components. The mains wire connection will be found towards the top of the unit. The power supply **MUST** be a fused switched spur.

12.2 Earthing

The unit **MUST be earthed** and a facility is provided for this in the design. The unit **MUST** be installed by qualified engineers and electricians. Water Hotter will not accept responsibility for units that are not fitted by appropriately

qualified installers. Failure to have the unit fitted by a suitably qualified installer will invalidate the warranty/guarantee of the unit.

13.0 OPERATING THE UNIT

Control Panel

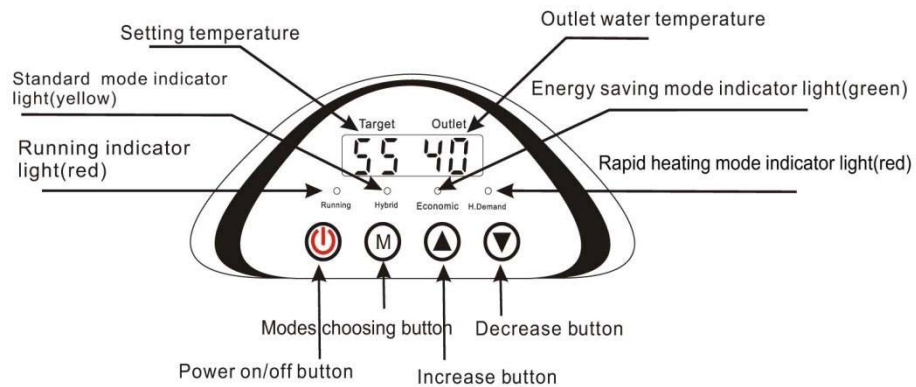

Power On

When the unit is powered on, the unit will either be in stand-by or running depending upon the state when it was turned-off. When the unit is in stand-by mode, the red light is off.

Viewing Modes

Repeatedly pressing the Mode Button will allow you to toggle between different energy modes.

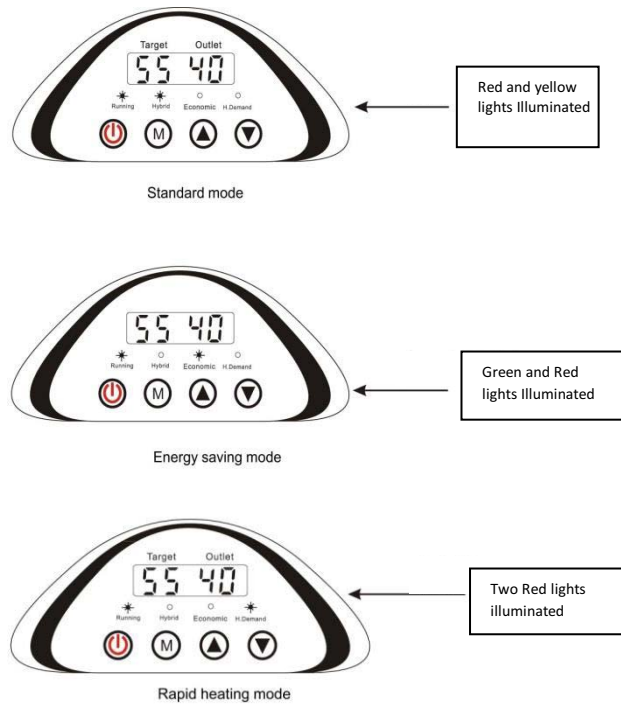

The three different modes operate as following:

1 **Standard mode:** When the 'running' and the 'hybrid' lights are illuminated, the unit is in the standard mode. This is the recommended mode and should be suitable year-round.

2 **Energy saving mode:** When the 'running' and the 'economic' lights are illuminated, the unit is in energy saving mode. In this mode, water is being heated by the heat pump alone. This setting is suitable when the ambient air temperature is above 10°C.

3 **Rapid heating mode:** When the 'running' and the 'H Demand' lights are illuminated, the unit is in high demand mode. In this mode, both the heat pump and the 1kW immersion heater are used. This mode is suitable for urgent hot water needs only.



Modes can be selected according to the actual demand but it is strongly suggested that standard mode is used the majority of the time.

Power on/Power off

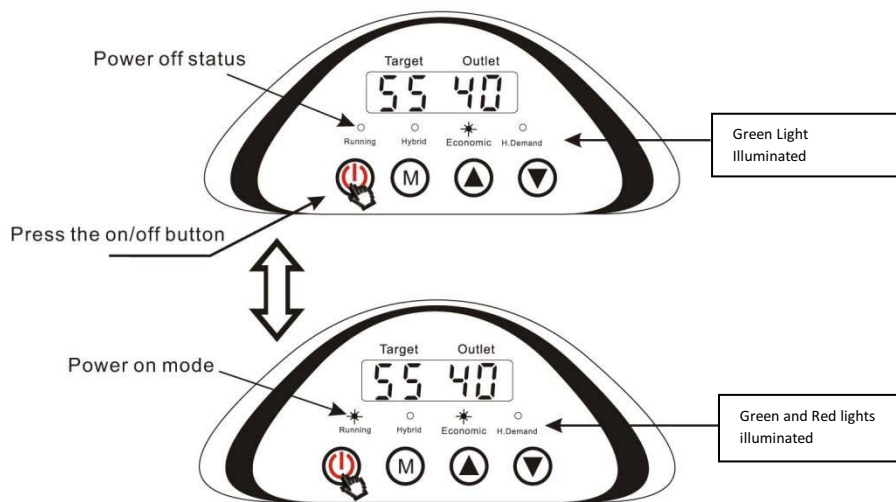
 is the power switch. When the unit is operating, the indicator light is illuminated.



Parameter setting

Power on and press "" to rise the set point (the target water temperature), press the "" to decrease the set point. The factory setting for the water temperature is 55°C and you are advised not to change it.

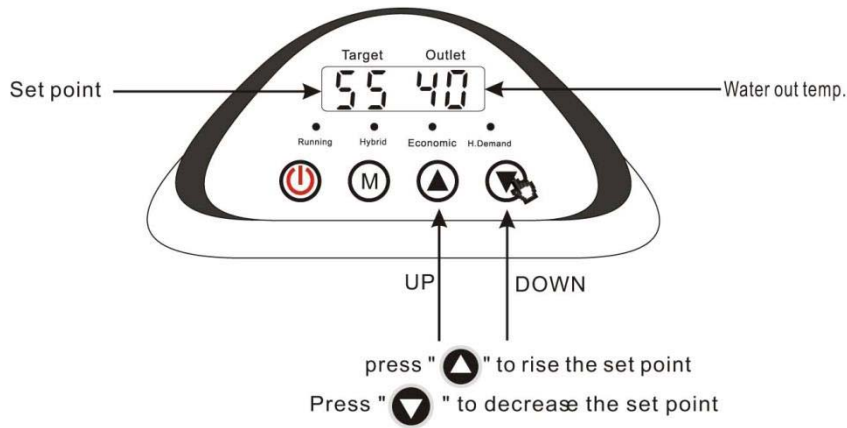

Set point automatic regulation

The default setting is automatic mode during which the unit will change the set point to follow the ambient air temperature automatically to account for seasonal variations. Decreasing the set point can save energy in summer and the set point will rise automatically in winter. The set point can also be changed manually. Use the up or down arrow keys to set the hot water temperature. The automatic mode is disabled by changing the set point manually. Press the mode key for 10 seconds will re-enable automatic mode.

The unit is pre-set to the recommended setting for all parameters. Should you wish to change these settings, you would be advised to discuss your decision with the Water Hotter technical team. The default settings are as follows:

Function	Parameter	Default
Target set point	0	55°C
Return temperature difference	1	5°C
Set point for elec. Heater	2	55°C
If temp is not reached within this time, elec heater will boost.	3	40
Target temp. for weekly sterilization	4	60°C
Time for sterilization	5	0min
Defrosting time	6	45min
Evaporator Trigger Temp. For defrost cycle	7	-3°C
Trigger temp to end defrost cycle.	8	13°C
Defrost cycle period.	9	8min
Adjustment for the elec. Expansion valve	10	1
Target degree of superheat	11	5°C
Steps of elec. Expansion valve	12	35
Use elec. Heater instead of compressor	13	0
Temp. to use elec. Heater instead of compressor	14	5°C
Energy saving defrosting	15	0
Min. time for energy saving defrosting	16	3min
Power off memory	17	1
Time to start sterilization (Midnight)	18	0h
Days to start sterilization (Weekly)	19	7d
Temperature compensation	20	0
Ambient temp. to start temperature compensation	21	15°C
Max. error for temperature compensation	22	5°C
Coefficient for temperature compensation	23	0.8°C

Notes:

Engineer Only Setting



14.0 TROUBLESHOOTING

Fault	Display Code	Reason	Solution
Turn on			
Running			
Bottom sensor failure	P 01	The sensor is open or short circuit	Check and replace the bottom temp. sensor
Upper sensor failure	P 02	The sensor is open or short circuit	Check and replace the upper temp. sensor
Coil sensor failure	P 03	The sensor is open or short circuit	Check and replace the coil temp. sensor
Suction sensor failure	P 04	The sensor is open or short circuit	Check and replace the suction temp. sensor
Ambient sensor failure	P 05	The sensor is open or short circuit	Check and replace the ambient temp. sensor
High pressure protection	E 01	The high pressure is over 21bar or pressure switch is open.	Check connection and refrigerant system.
Low pressure protection	E 02	The low pressure switch is open.	Check connection and refrigerant system.
Thermal protection	E 03	Water temperature is more than 85°C.	Check if the vessel is full.
Communication failure	E 08	Communication cable is disconnected or there is strong interference near the unit.	Check the connection of the pcb.
Defrosting	Flash		

15.0 MAINTENANCE REQUIREMENTS

15.1 The Cylinder

To ensure the continued optimum performance of the Water Hotter, it should be regularly maintained. This is of particular importance in hard water areas or where the water supply contains particulate matter. Maintenance should be carried out by a suitably qualified plumber/engineer and any replacement parts used must only be Water Hotter recommended spare parts. It is recommended that maintenance is carried out every 12 months on the cylinder and includes the checks detailed in this manual. If you are in a hard water area, you should check the magnesium sacrificial anode deterioration within 6 months of commissioning of the unit and annually 12 months after. You will be able to see the rate at which deterioration is happening and set a date for a full inspection when it is clear that a new magnesium anode is likely to be needed. Keeping a functioning magnesium anode is critical to the longevity of the unit. If you run the unit without the

anode you will invalidate the warranty/guarantee and the stainless steel cylinder may be seriously damaged.

In hard water areas consideration should be given to periodically descaling the immersion heater elements. To do this the unit will need to be drained; Paragraphs 16.4 to and 16.6 below detail how to drain the unit and remove the immersion heater(s).

Please check the condition on the magnesium anode during any servicing/maintenance and fit a new anode, if required.

15.2 Safety Valves

Slowly open the Temperature and Pressure Relief Valve by twisting its cap for a few seconds. Check that water is discharged and that it flows freely through the tundish and discharge pipework. Check valve reseats correctly when released.

NOTE : The water discharged may be very hot.

Repeat the procedure for the Expansion Relief Valve (located on the Cold Water Combination Valve or Expansion Valve Core Unit).

15.3 The Strainer

The in line strainer must be cleaned periodically by a suitably qualified engineer. The in-line strainer can be found inside the cold water combination group valve on unvented systems or alternatively a Y strainer on open vented systems. The engineer should:

- i) Wash any particulate matter from the inline strainer under clean running water.
- ii) Refit the inline strainer once totally clean or install a new one where necessary.

15.4 Draining the Unit

Switch off the electrical supply to the unit. Turn off the mains water supply to the unit. Attach a hosepipe to the drain cock having sufficient length to take waste water to a suitable discharge point below the level of the unit, at least one metre below the unit is recommended. Open the hot water tap nearest to the unit to relieve the system pressure. Open the drain cock. If water fails to drain from the unit, vent it by manually opening the Temperature/ Pressure Relief Valve or “crack a joint” in the unit plumbing to prevent the creation of a vacuum that may prevent effective draining.

15.5 Descaling the Immersion Heater

Once the unit has been drained and the power supply disconnected, open the cover to the immersion heater housing and disconnect wiring from immersion heater. Remove the thermostat by carefully pulling it outwards from the immersion heater. Unscrew the immersion heater back nut and remove the immersion heater from the unit. Over time the immersion heater gasket may become stuck to the mating surface. To break the seal insert a round bladed screwdriver into one of the pockets on the immersion heater and gently lever up and down.

Carefully remove any scale from the surface of the element. **DO NOT** use a sharp implement as damage to the element surface could be caused. Ensure that all sealing surfaces are clean and that the seals are undamaged; if in doubt fit a new gasket.

Replace immersion heater ensuring that the lower (right angled) element hangs vertically downwards towards the base of the unit. It may be helpful to support the immersion heater using a round bladed screwdriver inserted into one of the thermostat pockets whilst the back nut is tightened. Replace the thermostat(s) by carefully plugging the two male spade terminations on the underside of the thermostat head into the corresponding terminations on the element.

Rewire the immersion heater. Close and secure terminal cover.

15.6 Refilling the System

DO NOT switch on the immersion heater or heat pump part until the system has been completely refilled. Close the unit drain tap. With the hot tap open, turn on the mains water supply. When water flows from the hot tap allow time to purge all the air and to flush through any disturbed particles. Turn off the hot tap and then open successive hot taps in system to purge any air. The electrical supply can now be switched on.

15.7 Log Book

Please complete the log book supplied with the Water Hotter, stating what has been done, the date of the service and the name/contact details of the servicing engineer.

15.8 Maintenance Requirements

There are no formal annual maintenance requirements. However, it is advisable to check annually that:

- a) The pressure and temperature relief valve is still functioning properly by turning the plastic black cap around to make sure that water comes out of the valve when the black cap is turned.
- b) All filters are clear of debris.
- c) The air outlet to outside to make sure that it is clear from foliage, nests, etc. and that the gravity vent is working.

Please note that the top can be removed (by a suitably qualified engineer/plumber) so that the evaporator can be cleaned of dust and any debris.

16.0 FAULT FINDING

The following table lists simple faults and actions that can be attempted to clear the fault. Please ensure that a suitably qualified and experienced engineer/plumber makes any diagnoses and carries out any testing and repair.

Fault	Possible Causes	Remedy
No hotwater flow or reduced flow rate	1) Mains cold water supply shut	Check and open isolation
	2) Line strainer blocked	Turn off mains water supply, remove and clean inline strainer
	3) Cold water combination valve fitted incorrectly	Check direction flow arrows on valve and correct in
	4) Size of service pipe too small	Upgrade service pipe to correct size
	5) Low mains water pressure	Check water pressure. Consult with local water authority if necessary
Water from hot taps is cold	1) Unit is turned off	Ensure unit is turned on.
	2) Unit is in holiday mode	Reset programmer to standard running parameter
	3) Check for error codes on Ecocent controller	Refer to manual error code sheet
	4) Parameter zero set to low	Reset parameter zero with up arrow to a max of 60°C
	5) All hot water has been exhausted	Turn on immersion heater manually to boost recovery time
Discharge from TPRV	1) Pressure above 7bar. Failure of pressure reducing set	Replace cold water combination group set
	2) Temperature above 90-95°C thermal probe activated	Ascertain reason for high temp and replace TPRV
	3) Water dripping from TPRV, Expansion vessel failure or discharged	Recharge expansion vessel or replace
Discharge from cold water combination group set (CWCGS)	1) Pressure above 6bar. Failure of pressure reducing set	Replace cold water combination group set
	2) Water dripping from CWCGS safety valve, Expansion vessel failure or discharged	Recharge expansion vessel or replace
Cloudiness in water	In some areas a cloudiness may be noticed in the hot water.	This is due to aeration of the water, is quite normal and will quickly clear.

17.0 GUARANTEE

Should any factory fitted Temperature and/or Pressure Relief Valve(s) or other safety device be tampered with or removed, or any recommended Temperature or Pressure Relief Valves/safety device be omitted, your

warranty/guarantee will be invalidated. Water Hotter will not take responsibility for any damage resulting from the tampering, howsoever caused, save where such exclusion is unlawful.

17.1 Guarantee Terms

Water Hotter warrants/guarantees the electrical parts, thermal controls and valves relating to the cylinder for a period of one year from the date of purchase, with the exception of normal wear-and-tear including any damage caused as a result of lime scale deposits.

The stainless steel vessel forming part of the cylinder is warranted/guaranteed for a period of five years against faulty manufacture or materials provided that:

- i) It has been properly installed by a qualified installer as per the instructions and recommendations contained in this manual and all relevant Codes of Practice and Regulations in force at the time of installation.
- ii) Any disinfection has been carried out in accordance with BS 6700.
- iii) It has not been modified in any way other than by Water Hotter.
- iv) It has only been used for the storage of wholesome water.
- v) It has not been installed in a location liable to be subjected to frost, nor has it been tampered with or been subjected to misuse or neglect.
- vi) No factory fitted parts have been removed for unauthorised repair or replacement.
- vii) Within 45 days of purchase the user completes and returns the certificate supplied to register the product.

The compressor in the heat pump is warranted/guaranteed for 2 years from the date of purchase. Remaining parts of the heat pump are warranted/ guaranteed for 1 year from the date of purchase. Evidence of purchase and date of supply must be submitted with any warranty/guarantee claim.

This warranty/guarantee is not valid for installations outside the United Kingdom or the Republic of Ireland.

Any warranty/guarantee is for replacement parts only.

The purchaser of the unit acknowledges that he/she has seen Water Hotter's conditions of supply and has understood them.

All of our units are RoHS approved units.

This guarantee does not affect your statutory rights.

18.0 ENVIRONMENTAL INFORMATION

This product is made from many recyclable materials, therefore at the end of its useful life, it should be disposed of at a Local Authority Recycling Centre in order to realise the full environmental benefits.

Please note:

The pace of product development is such that we reserve the right to change product specifications without notice. We do, however, strive to ensure that all information in this leaflet is accurate at the time of publication.

19.0 SPARE PARTS

Please call us on 020 8539 4707 if you require any spare parts.

